



WORLD ASSOCIATION OF FLORAL ARTISTS  
BARBADOS 2014-2017

12TH

**WORLD FLOWER SHOW**

19-25 June, 2017 - Lloyd Erskine Sandiford Centre  
Bridgetown, Barbados

**FLOWERS**  
*in Paradise*

## TABLE OF CONTENTS

Welcome

Registration **1**

Tickets for Additional Show Events **2**

Show Timetable **3**

Registration and Competitor Information **5**

International World Flower Show Rules **6**

Competitors Timetable **6**

Staging Regulations **7**

Additional Information **9**

Floor Plan Exhibit Hall **10**

Class Description **12**

Junior Class Rules **21**

Plant Supplies & Plant Health **22**

Demonstrations & Lectures **23**

Tours **26**

Hotel Accommodation **27**



## WAFA BARBADOS

1. President - Maurice Webster
2. Vice President - Jennifer Weetch
3. Secretary - Julie Alleyne
4. Treasurer - Annice Dalrymple
5. Show - Wayne Ramsay
6. Seminar - Joan Linton
7. Hospitality - Patricia Harte
8. Demonstrations&Exhibitions - Jessica Cadogan
9. Publicity - Heather Redman
10. Printing and Publications - Trevor Inniss

# WAFA BARBADOS

### **Message from The Wafa President**

The Wafa Barbados Committee is pleased to welcome you to the 12th World Flower Show, **"Flowers in Paradise"**. It is also an added pleasure as this is the first time the World Show is coming to this region. We, together with some of our stakeholders and partners, have planned a number of activities to introduce you to the characteristics of our Barbadian culture and heritage and natural beauty of our island home.

We invite you, through the demonstrations, floral art exhibits and competition, lectures and other social events to make this journey with us. We are sure that all of the competitors, designers and demonstrators will produce imaginative and spectacular designs that will energise all of our members to improve, nurture and encourage that special camaraderie that we all share as members of the International Floral Art Community as we get together for this the 12th International World Flower Show in Barbados.

***A Very Warm Welcome!!! Something's Happening!!!***

***Mr. Maurice Webster, Wafa President***



### **Message from The Show Chairman**

We invite all our friends from around the world to journey to **"Flowers in Paradise"** in our beautiful island for an exciting and unforgettable experience.

The show committee has worked diligently to create a schedule which we now introduce to you and we hope will stimulate your creativity and produce an outstanding collection of exhibits for the show.

Thank you for participating in this global event, we look forward to welcoming you all to Barbados in June 2017.

***Rev. Dr. Wayne Ramsay, Show Chairman***



## REGISTRATION (see FORM A)

**Registration is open to all. COMPETITORS MUST REGISTER (exceptions - Classes 2, 16 & 17).**

### REGISTRATION INCLUDES THE FOLLOWING:

- Season Tickets (4 day) entry to the Show
- Priority in allocation of tickets for show events
- Access to WAFA Lounge
- Flowers in Paradise WAFA Barbados floral art book
- Show Brochure
- Post Show Brochure
- Conference bag
- Official name badge

## COST OF REGISTRATION

Early Registration between 1 May – 30 September 2016 - **US\$280.00**

Associate Registration (non-competitor, book not included in package) - **US\$230.00**

Late Registration after 30 September 2016 - **US\$330.00**

Late Associate Registration - **US\$280.00**

## COMPETITION FEES (see FORM B)

(In addition to Full Registration fee)

Cost of entry to Imposed Class - **US\$160.00**

## COMPETITION FEES (see FORM B)

(Registration fee not required)

Cost of entry to Mail in Classes 2 & 17 - **US\$55.00**

Cost of entry to Junior Class 16 - **US\$25.00**

## ADMISSION TICKETS FOR NON-REGISTRANTS (see FORM B)

Pre-booked Season Ticket - **US\$120.00**

Pre-booked daily entry - **US\$35.00**

Non Pre-booked day - **US\$45.00**

Non Pre-booked Season Ticket (4 day) - **US\$140.00**

Pre-booked Groups 25+ - **US\$25.00**

Guided Private Tour of Show followed by morning coffee - **US\$60.00**

(Friday & Saturday morning 07:30 – 10:00)

## REGISTRATION PACK (to be collected from Registration Desk)

Flamboyant Room at following times:

Monday 19 June 09:00 – 18:00

Tuesday 20 June 09:00 – 18:00

Wednesday 21 June 09:00 – 12:00

**TICKETS FOR ADDITIONAL SHOW EVENTS (See Forms C and D)**

See full listing of activities:  
*Timetable - pages 3 & 4*

*All events except Gala - A Bajan Affair - will take place at LESC*

Wednesday21	June	18:00	<i>Grand Opening Ceremony, Awards &amp; Preview</i>	<b>US\$110.00</b>
Thursday22	June	11:00	<i>National Demonstrations</i>	<b>US\$65.00</b>
Thursday22	June	18:00	<i>International Demonstrations</i> Hong Kong United Kingdom	<b>US\$95.00</b>
Friday23	June	07:30	<i>Guided Tour of Show and Morning Coffee</i>	<b>US\$60.00</b>
Friday23	June	11:00	<i>Lecture: Barbados – The Gardens of Paradise, Past and Present</i>	<b>US\$25.00</b>
Friday23	June	18:00	<i>International Demonstrations</i> France United Kingdom	<b>US\$95.00</b>
Saturday24	June	07:30	<i>Guided Tour of Show and Morning Coffee</i>	<b>US\$60.00</b>
Saturday24	June	11:00	<i>Lecture: Gender and Social change in Post-Independent Barbados</i>	<b>US\$25.00</b>
Saturday24	June	19:00	<i>Gala: A Bajan Affair - Concorde Experience</i>	<b>US\$180.00</b>
Sunday25	June	10:00	<i>Religious Service</i>	<b>No Charge</b>
Sunday25	June	16:00	<i>Lecture: Bajan Folklore</i>	<b>US\$25.00</b>

**PHOTOGRAPHY**

The official photographer will automatically photograph First, Second, Third Prize, Special Award winners and Honorary Exhibits. Copies will be available for purchase at the Show.

Only hand-held cameras may be used, without separate lighting, tripods or other supports. Video cameras are not permitted. WAFA Barbados reserves the right to reproduce any photograph taken at this event.



# 12TH

## WORLD FLOWER SHOW FLOWERS IN PARADISE

Lloyd Erskine Sandiford Centre  
Barbados

### SHOW TIMETABLE: 19-25 JUNE 2017

#### Monday19

9:00 - 18:00

*Registration  
Collect pre-ordered plant material*

Flamboyant Room North  
Car Park

#### Tuesday20

9:00 - 18:00

*Registration continues  
Collect pre-ordered plant material  
Staging of International Honorary Exhibits  
Judges Briefing Seminar  
Staging of Junior classes  
Receipt of exhibits for Mail-in Class  
Competitors deposit staging materials  
2015 WAFA Seminar Reunion*

Flamboyant Room North  
Car Park  
Main Foyer

9:00 - 15:00

9:00 - 16:00

16:00 - 20:00

17:00 - 19:00

17:00 - 19:00

18:00 - 21:00

Door D  
Doors B, D  
Doors A,B,C,D  
Sugar Mill Restaurant

#### Wednesday21

6:00 - 11:00

8:00 - 11:00

9:00 - 12:00

11:00 - 12:00

12:00 - 17:00

18:00 - 22:00

*Staging of Competitive Exhibits  
Staging of Imposed Classes  
Registration Continues  
Judges Luncheon  
Judging of Competitions  
Opening Ceremony, Awards and Preview*

Doors A,B,C,D  
Doors A, C, D  
Flamboyant Room North  
Sugar Mill Restaurant  
All Floors  
Flamboyant Room

#### Thursday22

7:30 - 8:30

8:30 - 10:00

10:00 - 11:00

10:00 - 22:00

10:00 - 22:00

11:00 - 13:00

*Maintenance of Exhibits  
Competitors/Judges Session  
Judges De-briefing  
Public Viewing - Flowers in Paradise  
Vendors Market  
National Demonstrations  
Joan Linton - Heritage  
Jennifer Weetch - A Floral Journey  
Anthony Tang Kai - Tropical Splendour*

All Floors  
All Floors  
Marigold Room  
  
Outdoors  
Flamboyant Room

18:00 - 20:00	<b><i>International Demonstrations</i></b> Hong Kong: Dr. Solomon Leong UK: Craig Bullock	Flamboyant Room
<b>Friday 23</b>		
7:30 - 8:30	<b><i>Maintenance of Exhibits</i></b>	All Floors
7:30 - 10:00	<b><i>Guided Private Tour and Morning Coffee</i></b>	All Floors
10:00 - 22:00	<b><i>Public Viewing - Flowers in Paradise</i></b>	
10:00 - 22:00	<b><i>Vendors Market</i></b>	Outdoors
11:00 - 12:30	<b><i>Lecture: Professor Sir Henry Fraser</i></b> Barbados – The Gardens of Paradise, Past and Present	Flamboyant Room North
18:00 - 20:00	<b><i>International Demonstrations</i></b> France: Marie Françoise Déprez UK: William Dixon	Flamboyant Room
<b>Saturday 24</b>		
7:30 - 8:30	<b><i>Maintenance of Exhibits</i></b>	All Floors
7:30 - 10:00	<b><i>Guided Private Tour and Morning Coffee</i></b>	All Floors
10:00 - 22:00	<b><i>Public Viewing - Flowers in Paradise</i></b>	
10:00 - 22:00	<b><i>Vendors Market</i></b>	Outdoors
10:00 - 16:00	<b><i>WAFB General Assembly</i></b>	Flamboyant Room South
11:00 - 12:30	<b><i>Lecture: Professor Eudine Barriteau</i></b> Gender and Social Change in Post-Independent Barbados	Flamboyant Room North
19:00 - 01:00	<b><i>Gala - A Bajan Affair</i></b>	Concorde Experience
<b>Sunday 25</b>		
7:30 - 8:30	<b><i>Maintenance of Exhibits</i></b>	All Floors
10:00 - 20:00	<b><i>Public Viewing - Flowers in Paradise</i></b>	
10:00 - 20:00	<b><i>Vendors Market</i></b>	Outdoors
10:00 - 11:30	<b><i>Religious Service – Flag Procession</i></b>	Flamboyant Room
16:00 - 17:30	<b><i>Lecture: Mr. Addington Forde</i></b> Bajan Folklore	Flamboyant Room
20:00	<b><i>Close of Show</i></b>	
20:30 - 22:00	<b><i>Dismantling of Exhibits</i></b>	



## REGISTRATION AND COMPETITOR INFORMATION

- Registration is open to all. **COMPETITORS MUST REGISTER**  
Online registration is required. *(See page 1)*
- Registration fees must be paid at time of online registration. Please retain a copy for your records.
- All applications for class entry must be received by 30 September 2016.
- Accepted competitors will be notified by 30 October 2016.
- Reconfirmation of entry by competitor is required by email no later than 8 December 2016.
- Only one entry per competitor will be accepted but please indicate 1st, 2nd and 3rd choices on application form.
- Imposed Classes 11, 14 & 18 require **US\$160.00** payment in addition to Registration Fee.
- Mail-in Classes 2 & 17 do not require payment of Registration Fee but are required to pay a Competitors entry Fee of **US\$55.00**.
- Junior Class 16 is not required to pay the Registration Fee but is required to pay a Competitors entry Fee of **US\$25.00**.
- All exhibits will be staged in artificial lighting.
- Judging will take place from 12:00 – 17.00 on Wednesday 21 June 2017.
- In addition to Special Awards, prizes will be presented to First, Second and Third in each class.
- The Judges will be available for informal discussions between 08.30 – 10.00 on Thursday 22 June 2017.

*Competitive classes are open to individual exhibitors who are members of a floral art society/national association represented in WAFA.*

*Class 16: Open to non-WAFA members*

*Class 20 is open to WAFA and non-WAFA Juniors.*



## INTERNATIONAL WORLD FLOWER SHOW RULES

1. *An exhibit is made of plant material, with or without accessories, WITHIN a space specified in the Show Schedule.*
2. *Plant material must predominate over all other components of the exhibit.*
3. *The use of artificial plant material is forbidden unless stated in the regulations.*
4. *Fresh plant material must be in water or water-retaining material unless such material remains turgid throughout the event.*
5. *Painted and/or artificially coloured plant material may be used unless otherwise stated in the regulations.*
6. **PRE-PREPARED WORK MUST NOT PREDOMINATE IN THE EXHIBIT.**

## COMPETITORS TIMETABLE

Friday	30 September 2016		<i>Last date for receipt of competition entries</i>
Friday	09 December 2016		<i>Last date for competitors to confirm acceptance of their allocated classes</i>
Monday	19 June 2017	09.00 – 18.00	<i>Competitors pre-ordered plant material available for collection at LESC</i>
Tuesday	20 June 2017	09.00 – 18.00	<i>Competitors pre-ordered plant material available for collection at LESC</i>
Tuesday	20 June 2017	17.00 – 19.00	<i>Receipt of exhibits for Mail-in Classes 2 &amp; 17 &amp; Junior Mail-in Class 16, LESC</i>
Tuesday	20 June 2017	17.00 – 19.00	<i>Competitors deposit staging materials – LESC. Badges must be shown.</i>
Wednesday	21 June 2017	06.00 – 11.00	<i>Staging of competitive exhibits except Classes 11, 14 &amp; 18.</i>
Wednesday	21 June 2017	08.00 – 11.00	<i>Staging of Imposed Classes 11, 14 &amp; 18</i>
Wednesday	21 June 2017	12:00 – 17.00	<i>Judging of Competitions</i>
Wednesday	22 June 2017	18.00 – 22.00	<i>Opening, Preview and Awards Ceremony - Flamboyant Room</i>
Thursday	22 June 2017	08.30 – 10.00	<i>Judges will be available for informal discussion</i>
Sunday	25 June 2017	20.30 – 22.00	<i>Dismantling of exhibits Strictly NO admittance if badge is not shown.</i>



## STAGING REGULATIONS

***Competitors unable to fulfill their commitments must notify the WFA Barbados Secretariat (email: [competitions@wfabarbados.com](mailto:competitions@wfabarbados.com)) in advance of the show. There will be no refund of the Registration Fee or Competition Entry Fee for Imposed, Mail-in Classes or Junior Class.***

- All Competitive Classes (except Classes 2, 16 & 17 must be staged in situ by the competitor, who must use the specified staging. Attachments to and moving of, the staging is not permitted unless specified in the particular class.
- Competitors may use pre-constructed or pre-woven plant material but it may not be a dominant component of the exhibit. Items requiring special time or expertise for their preparation may be brought ready assembled for incorporation in any exhibit, but may not dominate.
- Competitors' badges MUST be worn at all times.
- Only competitors and officials will be allowed in the halls during staging times.
- Staging time for competitive exhibits (except Classes 2 & 17, Imposed Classes 11, 14, & 18, Juniors Class 16 will be strictly enforced from 06.00 – 11:00 on Wednesday 21 June 2017.
- Imposed Class competitors, Classes 11, 14 & 18 MUST stage their entries from 08.00 – 11:00.
- Exhibits for Classes 2, 16 & 17 may be pre-posted or hand delivered to the venue, Tuesday 20 June between 17.00 – 19.00.

Information to be supplied when accepted into Class.

- No help may be given regarding preparation or construction of an exhibit (except if required to lift a heavy object, and only then at the discretion of a show official).
- Although every care is taken to ensure accuracy, all measurements in the staging instructions are approximate. All exhibits must be staged within the space provided, using the specified staging, unless otherwise indicated in the schedule. Attachments to and moving of staging is not permitted.
- Competitors must place their waste material in bags provided by the Show Committee and remove it from the hall.
- Aerosol / spray painting is NOT permitted in the halls.
- Competitors wishing to use electrical equipment, please note that the Supply is 110 Volts 50 cycles.
- Competitors may not bring any refreshments into the halls. Light refreshments will be available.
- Judging will be conducted according to the International World Show Rules and Regulations in this schedule.

- No persons other than Judges, their Stewards and Show Officials will be permitted in the halls whilst judging is in progress.
- The decisions of the Judges' Panel are final.
- Competitors are required to maintain their exhibits in prime condition for the duration of the show. Maintenance of exhibits may be carried out from 07.30 – 08.30 each morning. The Committee reserves the right to change or remove faded plant material.
- All Competitors' property is at their own risk and they must be responsible for their own insurance, if deemed necessary. **The Barbados Association of Floral Artists (BAFA) and the World Association of Floral Artists (WAFA)** do not accept any liability for loss or damage to any of the competitors' property.
- Dismantling time for all competitors is Sunday 25 June, from 20.30 – 22.00. To ensure security of competitors and their property, the halls will be vacated completely from 20.00 – 20:25 except for members of WAFA Barbados Show Committee. Competitors wearing badges will be admitted at 20:30. Any exhibits or parts thereof remaining unattended in the halls after 22.00 will be deemed abandoned and will be disposed of.
- Agreement to the above Regulations is declared by completing the Registration Form.

***For queries please contact:***

***WAFA Barbados Secretariat  
Suite 104F, BIDC Bldg #2  
Harbour Road  
St. Michael***

***Email: [info@wafabarbados.com](mailto:info@wafabarbados.com)  
Tel: (246) 622-2421***



## ADDITIONAL INFORMATION

Plant Suppliers and Plant Importation – *Please see pages 22.* Dried, skeletonized, glycerined, bleached, additionally coloured and manipulated plant material is considered natural.

### *Definition: Foliage*

*The leaves of any plant.*

*Immature, unopened buds NOT showing petal colour.*

*Flowerless bracts are acceptable but they should NOT predominate in exhibits where there is a requirement to feature foliage.*

*Also flowerless grasses, equisetum, cacti/succulents, lichens, mosses*

*This definition may not necessarily be botanically correct but it should be accepted for the purposes of this competitive show.*

### **REGISTRATION**

Wafa Barbados Secretariat  
Suite 104F, Bldg #2  
Harbour Road  
St. Michael

Email: [registration@wafabarbados.com](mailto:registration@wafabarbados.com)

### **COMPETITION ENQUIRIES**

Wafa Barbados Secretariat  
Suite 104F, Bldg #2  
Harbour Road  
St. Michael

Email: [competitions@wafabarbados.com](mailto:competitions@wafabarbados.com)

# FLOOR PLAN - GROUND FLOOR

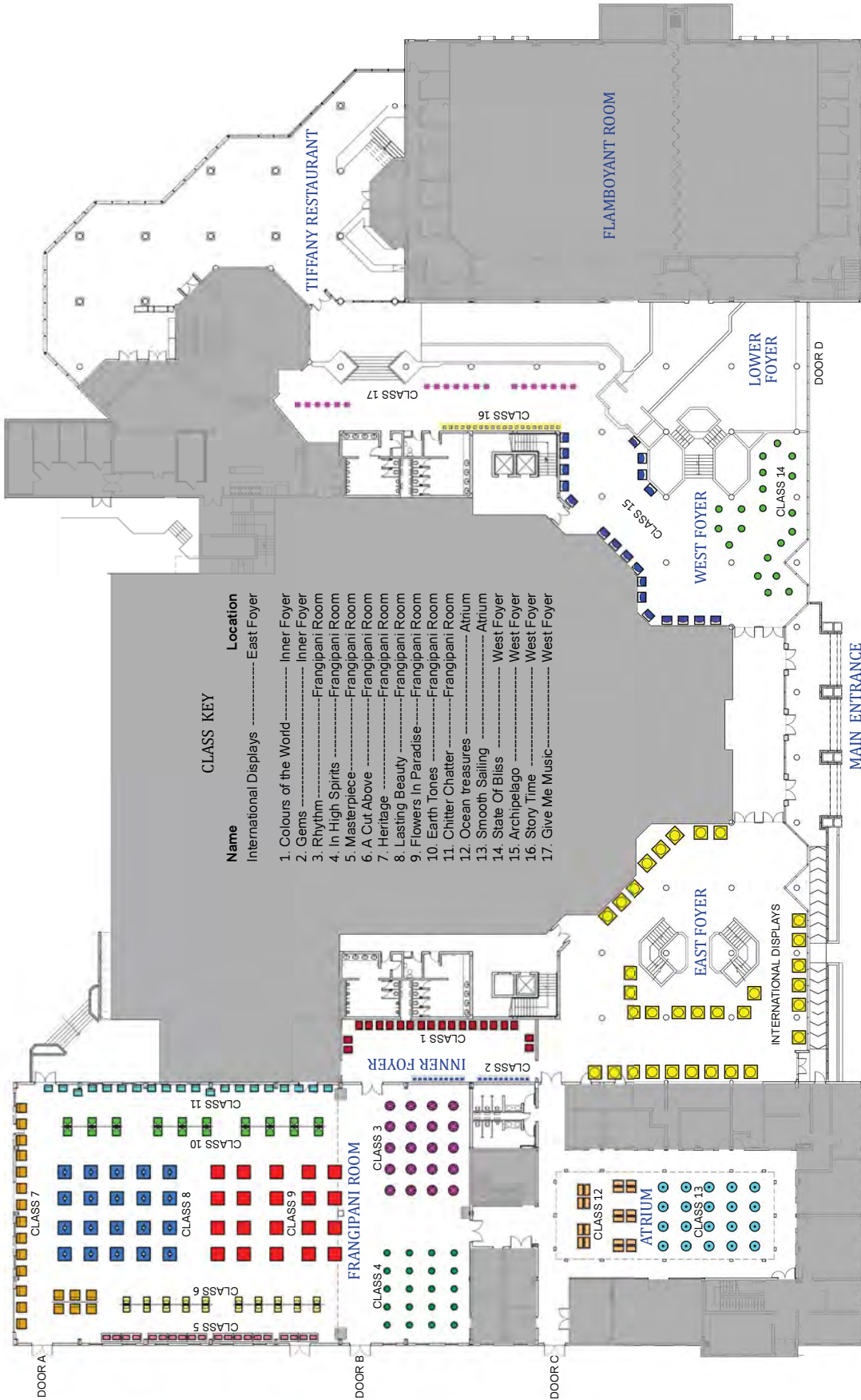

# FLOOR PLAN - FIRST FLOOR

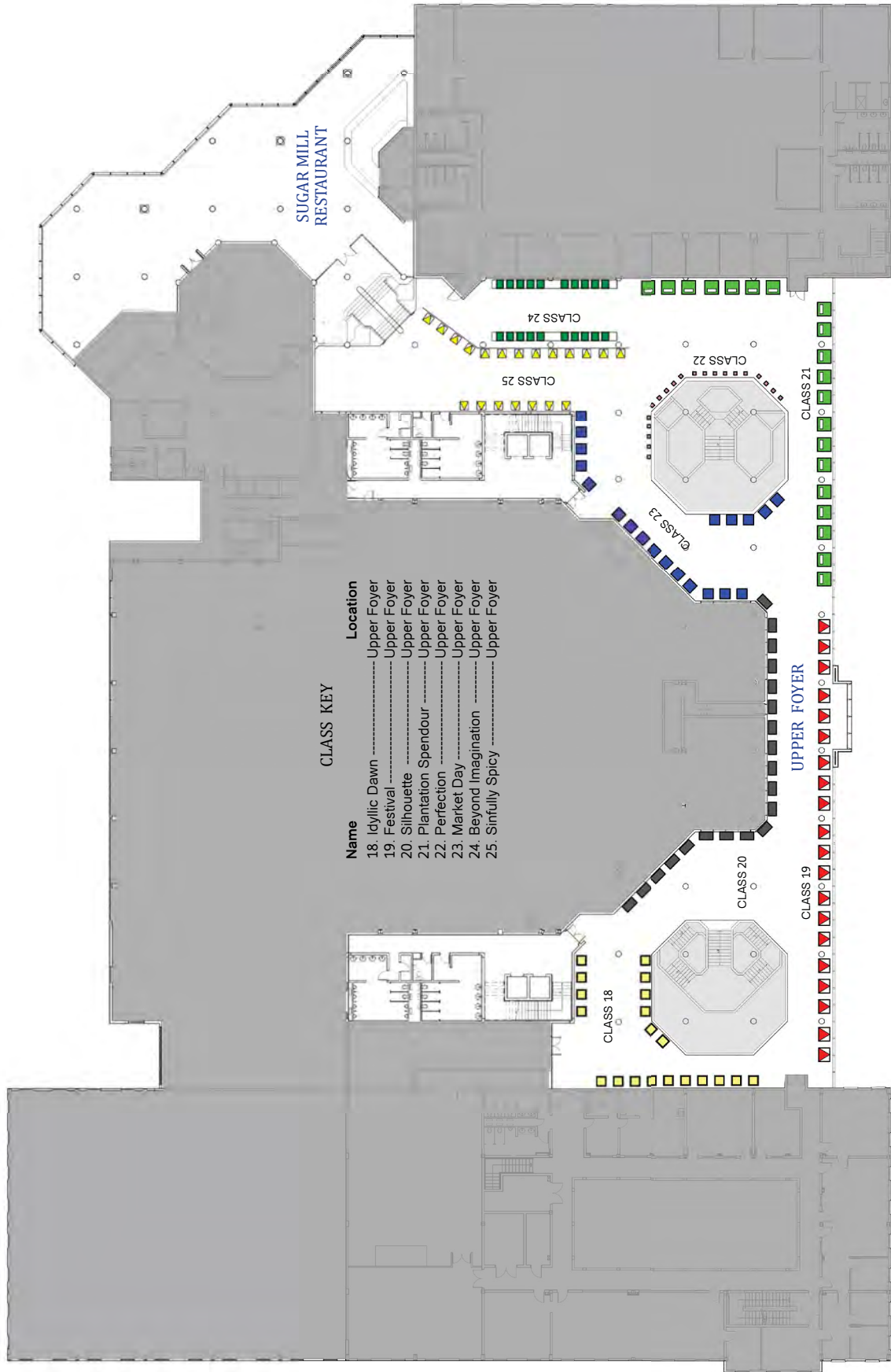

## Important Note

All competitive exhibits are to be constructed entirely in the halls during staging time unless otherwise stated in the Show Schedule. Items requiring special time or expertise for their preparation may be brought ready assembled for incorporation in any exhibit but these items **SHOULD NOT BE PREDOMINANT IN THE EXHIBIT.**

**PLEASE NOTE ALL MEASUREMENTS ARE IN CENTIMETRES.**

## 1. COLOURS OF THE WORLD

### An Exhibit

#### Space Allowed

Width: 61 cm

Depth: 75 cm

Height: Optional

Staging: Draped tabling 74 cm from floor

Colour: Champagne

Background: A drape length 244 cm from floor

Colour: Champagne

Judged from the front

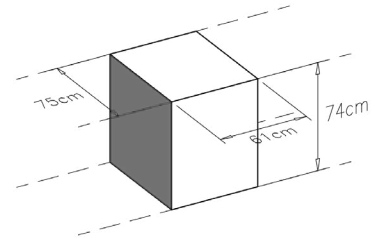

## 2. GEMS

### Craft - Mail-in Class. An Exhibit

#### No fresh plant material

#### Space Allowed

Width: 24 cm

Depth: 34 cm

Height: 10 cm

Staging: Draped tabling 110 cm from floor, with a back 15 cm high

Colour: Blue

Judged from the front

*To be brought or mailed in ready assembled for staging by the Show Committee.*

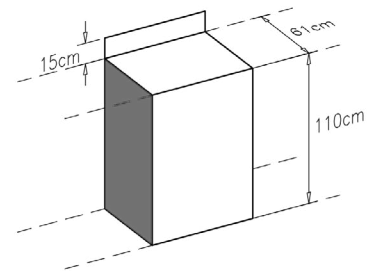

## 3. RHYTHM

### An Exhibit featuring foliage

#### Space Allowed

Diameter: 91.5 cm

Height: Optional

Staging: A circular base

diameter 91.5 cm, thickness 3 cm

Staging Colour: Grey

Judged from all around

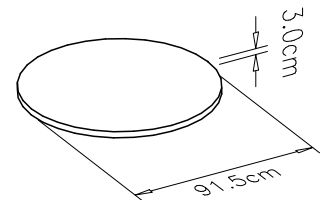

#### 4. IN HIGH SPIRITS

*An Exhibit*

**Space Allowed**

Diameter: 76 cm

Height: Optional

Staging: A rum barrel with six metal straps

Diameter at base and top 56 cm

Largest circumference 202 cm

Colour: Brown

Judged from all around

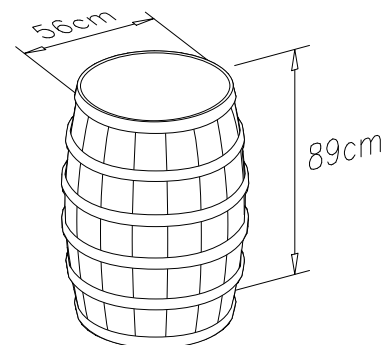

#### 5. MASTERPIECE

*An Exhibit*

**Space Allowed**

Width: 66 cm

Depth: 61 cm from front edge of frame

Height: 61 cm

Staging: A frame fixed 14 cm from front edge of draped tabling 74 cm from floor

Frame width 66 cm, height 61 cm, thickness 5 cm

Colour: Frame gold, tabling black

Background: A drape length 350 cm from floor

Colour: Black

Judged from the front

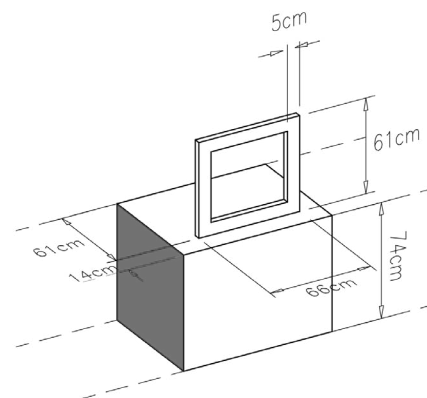

#### 6. A CUT ABOVE

*An Exhibit*

**Space Allowed**

Width: 61 cm

Depth: 61 cm

Height: 152 cm

Staging: A cube width 61 cm, depth 61 cm, height 61 cm

Colour: Grey

Background: A drape length 183 cm from floor

Colour: Grey

Judged from three sides

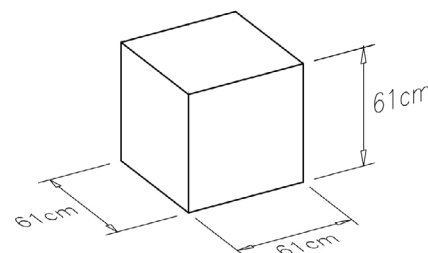



## 7. HERITAGE

### An Exhibit

#### Space Allowed

Width: 76 cm

Depth: 76 cm

Height: Optional

Staging: A plinth with a top

Plinth width 30 cm, depth 30 cm, height 76 cm

Top width 76 cm, depth 61 cm, thickness 1.2 cm

Colour: Brown

Background: A drape length 350 cm from floor

Colour: Champagne

Judged from the front

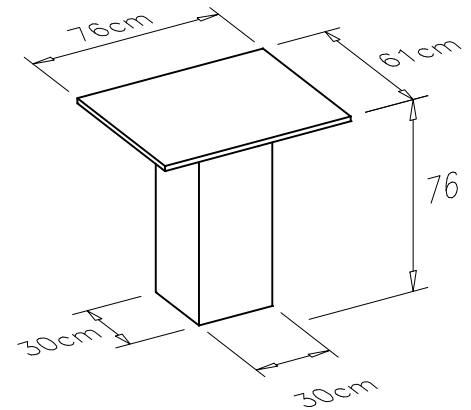

## 8. LASTING BEAUTY

### An Exhibit

#### Space Allowed

Width: 122 cm

Depth: 122 cm

Height: Optional

Staging: An open top column, with two horizontal dowels projecting from opposite sides, positioned centrally on a base

Column diameter 15.2 cm, height 183 cm

Dowel length 46 cm, diameter 2 cm

Dowel positioned 152.5 cm and 122 cm from floor

Maximum weight per dowel 700 g

Base width 40.5 cm, depth 40.5 cm, thickness 2 cm

Colour: Grey

Judged from all around

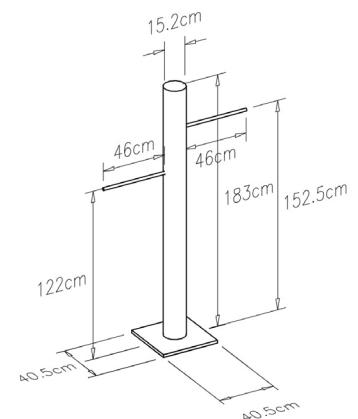

## 9. FLOWERS IN PARADISE

### An Exhibit

#### Space Allowed

Width: 122 cm

Depth: 101.6 cm

Height: Optional

Staging: A base width 122 cm, depth 101.6 cm, height 10 cm

Colour: Black

Judged from all around

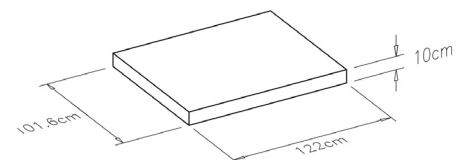

**10. EARTH TONES**

*An Exhibit*

**Space Allowed**

Width: 76 cm

Depth: 76 cm

Height: 183 cm

Staging: A cube width 76 cm, depth 76 cm,  
height 76 cm

Colour: Champagne

Background: A drape length 183 cm from floor

Colour: Champagne

Judged from three sides

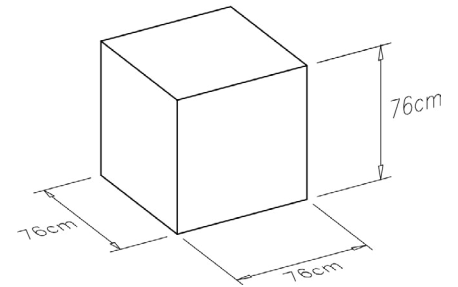

**11. CHITTER CHATTER**

*Imposed Class*

**Space Allowed**

Width: 60 cm

Depth: 30 cm

Height: Optional

Staging: A vertical wooden panel, with an L-shaped  
hook, attached to the centre of a base  
Panel width 29 cm, depth 1.5 cm, height 183 cm  
Hook length 3.8 cm, affixed 15.2 cm from top  
Base width 40.5 cm, depth 40.5 cm, height 15.2 cm  
Colour: Natural pine

Background: A drape length 350 cm from floor

Colour: Champagne

Judged from the front

*Preference will be given to overseas Wafa members.*

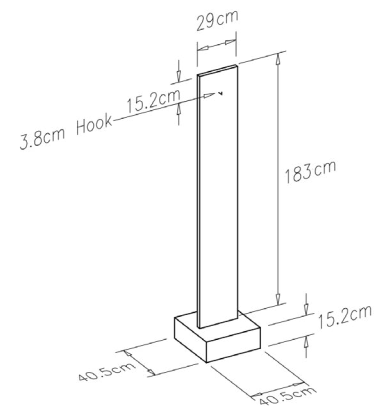

**12. OCEAN TREASURES**

*An Exhibit*

**Space Allowed**

Width: 88 cm

Depth: 38 cm

Height: 61 cm

Staging: A niche with lighting on draped  
tabling 100 cm from floor  
Niche width 88 cm, depth 38 cm,  
height 61 cm, thickness 2.5 cm

Colour: Blue

Judged from the front

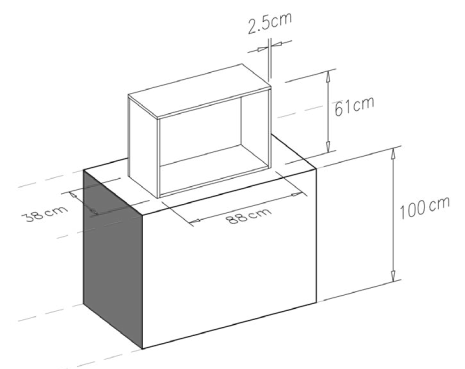

**13. SMOOTH SAILING**

*An Exhibit*

**Space Allowed**

**Diameter:** 91.5 cm

**Height:** Optional

**Staging:** A base diameter 91.5 cm, thickness 2.5 cm

Colour: Grey

Judged from all around

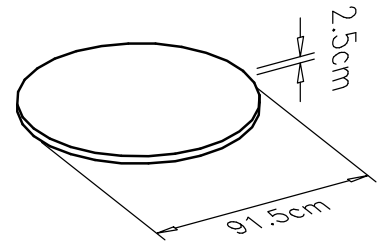

**14. STATE OF BLISS**

*Imposed Class*

**Space Allowed**

**Diameter:** 91.5 cm

**Height:** Optional

**Staging:** A wooden spool with a top  
 Spool diameter 60 cm, height 43 cm  
 Top diameter 91.5 cm, thickness 1.5 cm  
 Colour: Orange

Judged from all around

*Preference will be given to overseas Wafa members.*

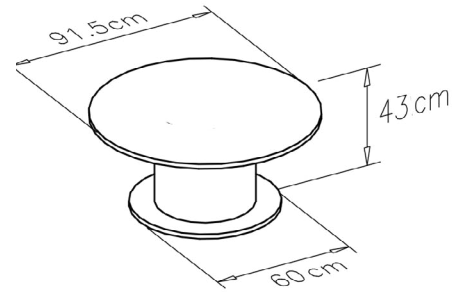

**15. ARCHIPELAGO**

*An Exhibit*

**Space Allowed**

**Width:** 91 cm

**Depth:** 76 cm

**Height:** Optional

**Staging:** Two staggered metal frames containing mesh, affixed to a pole on a base  
 Frames width 31 cm, height 66 cm  
 Lower frame 45 cm from floor, upper frame 111 cm from floor  
 Mesh 5 cm squares  
 Pole height 179 cm  
 Base width 30.5 cm, depth 30.5 cm, height 1.5 cm  
 Colour: Black

**Background:** A drape length 244 cm from floor

Colour: Black

Judged from the front

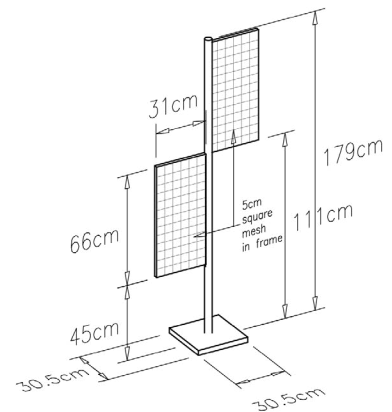

### 16. STORY TIME

Junior Mail-in Class: a. Ages 8-11yrs  
b. Ages 12-16yrs

Fresh or dried plant material

#### Space Allowed

Width: 25 cm

Depth: 25 cm

Height: 25 cm

Staging: Tabling 120 cm from floor with a back 41 cm high

Colour: Yellow

Judged from the front

To be brought or mailed in ready assembled for staging  
by the Show Committee

Open to Wafa and non-Wafa juniors.

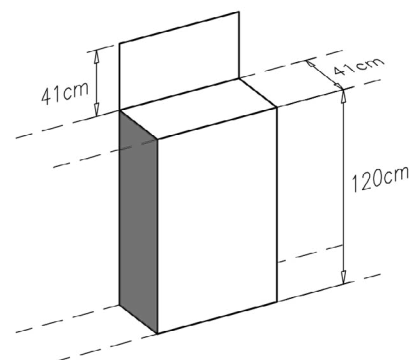

### 17. GIVE ME MUSIC

Mail-in Class

A Mobile exhibit featuring fresh or dried material

#### Space Allowed

Width: 41 cm

Depth: 41 cm

Height: Optional

Staging: A hook on a chain hung from a horizontal metal  
rod 180 cm from the floor

Chain length 30 cm

Colour: Gold

Judged from all around

To be brought or mailed in ready assembled and must include a ring  
for mounting by the Show Committee.

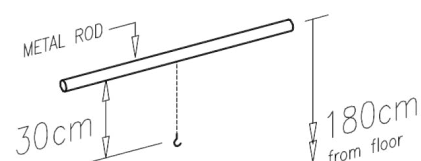

### 18. IDYLLIC DAWN

Imposed Class

#### Space Allowed

Width: 76 cm

Depth: 76 cm

Height: Optional

Staging: A draped table, width 76 cm, depth 76 cm, height 74 cm

Colour: Black

Background: A drape length 244 cm from floor

Colour: Black

Judged from the front

Preference will be given to overseas Wafa members.

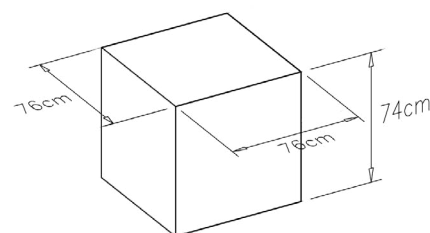

**19. FESTIVAL**

*An Exhibit*

**Space Allowed**

**Width:** 122 cm

**Depth:** 101.6 cm

**Height:** Optional

**Staging:** A base width 122 cm,  
 depth 101.6 cm, height 10 cm

Colour: Grey

**Background:** A drape length 244 cm from floor

Colour: Grey

Judged from the front

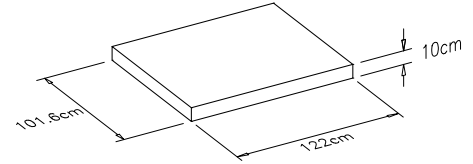

**20. SILHOUETTE**

*An Exhibit*

**Space Allowed**

**Width:** 97 cm

**Depth:** 75 cm

**Height:** Optional

**Staging:** Draped tabling 74 cm from floor

Colour: Black

**Background:** A drape length 244 cm from floor

Colour: Black

Judged from the front

*Open to WAFAs and Non-WAFAs members.*

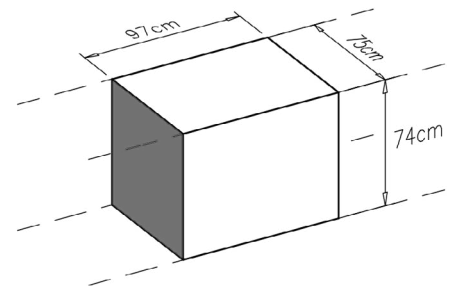

**21. PLANTATION SPLENDOUR**

*A Pedestal Exhibit*

**Space Allowed (Defined by tape on floor)**

**Width:** 122 cm

**Depth:** 122 cm

**Height:** 244 cm

**Staging:** Pedestal supplied by exhibitor or  
 by Show Committee on request

**Background:** A drape length 244 cm from floor

Colour: Grey

Judged from the front

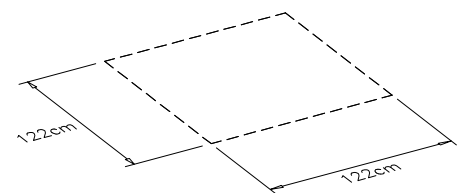

## 22. PERFECTION

*An Exhibit*

### Space Allowed

Width: 30.5 cm

Depth: 30.5 cm

Height: 30.5 cm

**Staging:** A circular plinth on a square base with a square mirrored top

Plinth diameter 25.5 cm, height 101.6 cm

Mirrored top width 30.5 cm, depth 30.5 cm, thickness 1.5 cm

Colour: Green

Viewed from all around and judged from the front.

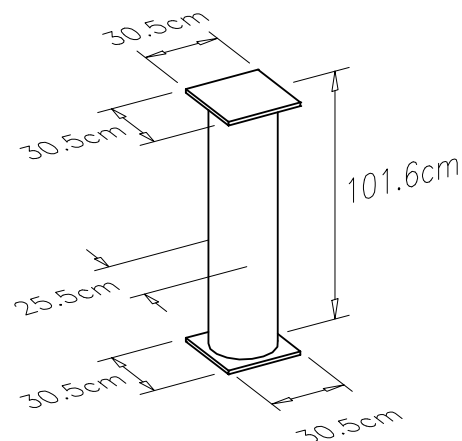

## 23. MARKET DAY

*An Exhibit*

### Space Allowed

Width: 91.5 cm

Depth: 91.5 cm

Height: Optional

**Staging:** A base width 91.5 cm, depth 91.5 cm, thickness 1.5 cm

Colour: Terracotta

**Background:** A drape length 244 cm from floor

Colour: Champagne

Judged from the front

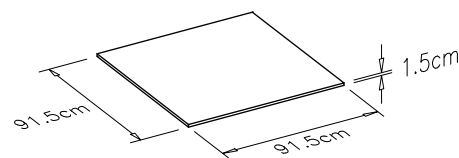

## 24. BEYOND IMAGINATION

*An Exhibit*

### Space Allowed

Width: 61 cm

Depth: 75 cm

Height: Optional

**Staging:** Draped tabling 74 cm from the floor

Colour: Champagne

**Background:** A drape length 244 cm from floor

Colour: Champagne

Judged from the front

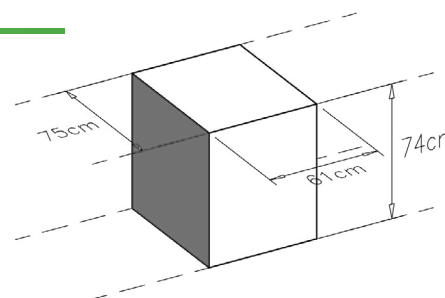

**25. SINFULLY SPICY**

*An Exhibit*

**Space Allowed**

**Width:** 76 cm

**Depth:** 76 cm

**Height:** Optional

**Staging:** A cube width 76 cm, depth 76 cm,  
height 76 cm

Colour: Gold

**Background:** A drape length 244 cm from floor

Colour: Gold

Judged from three sides

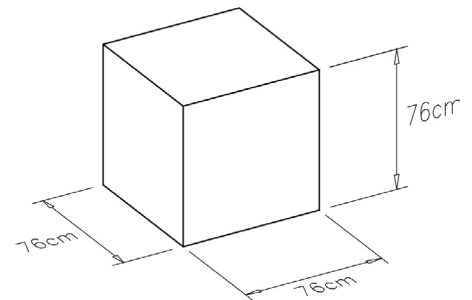

## **JUNIOR CLASS RULES**

1. Exhibit must be solely the work of the exhibitor.
2. An exhibit is made of plant material, with or without accessories, within the space allowed.
3. Plant material must predominate over all other components in the exhibit.
4. Fresh plant material, if used, must be in water or water retaining material unless the plant material will remain in good condition for the duration of the show.
5. Painted and/or artificially coloured plant material may be used.
6. The use of artificial plant material is forbidden.
7. Exhibits in Class 16 to be brought or mailed ready assembled for staging by the Show Committee. Please include label with competitor's name and address.
8. For reasons of Health & Safety, Junior exhibitors are not permitted in the halls during staging times.
9. Registration fee not required. Competition Entrance Fee payable **US\$25.00**.

### ***Enquiries to:***

***Wafa Barbados Secretariat  
Suite 104F, BDC Bldg #2  
Harbour Road  
St. Michael***

***Email: [info@wafabarbados.com](mailto:info@wafabarbados.com)***

***Tel: (246)622-2421***



## SUPPLIES OF PLANT MATERIAL

*Competitors are responsible for providing all their own plant material (except for the Imposed Classes 11, 14, & 18). The Wafa Barbados Management Committee is unable to assist competitors/exhibitors in any way.*

A supplier 'FOREVER FLOWERS' will deliver competitors'/exhibitors' preordered flowers for collection at the LESC at times indicated in the Show Timetable. Enquiries regarding plant availability and prices should be made directly with the supplier. Contact details –

*Ann Leacock*

Tel. No: 1(246) 435-9774

Fax: 1(246) 429-2694

Email: [foreverflowers@caribsurf.com](mailto:foreverflowers@caribsurf.com)

Please give clear instructions to the supplier to ensure that your order is delivered clearly labelled with competitor's name and class number. All payments must be made directly to the supplier and the **Wafa Barbados Management Committee** will not be involved in this in any way.

## PLANT HEALTH

Barbados has strict plant control regulations. For importation of cut flowers, foliage and parts of plants for decorative purposes please refer to the Plant Quarantine Division, Ministry of Agriculture, Food and Water Resource Management. Please note requirement for phytosanitary certificate for certain materials from countries outside of Barbados.

Details and forms will be placed online from May 1, 2016, and forms may be completed and returned to the Plant Quarantine Division via email at [plant\\_quarantine.agriculture.gov.bb](mailto:plant_quarantine.agriculture.gov.bb), and a copy sent to email [nppo.pq.bb@gmail.com](mailto:nppo.pq.bb@gmail.com)  
or

Mailed to:

Plant Quarantine Division  
Ministry of Agriculture, Food, Fisheries and Water Resource Management

Crumpton Street  
Bridgetown  
St. Michael  
Barbados  
West Indies

Tel: 1 (246) 426-1222

Fax: 1 (246) 426-6927



## INTERNATIONAL DEMONSTRATIONS

### **Demonstration 1 – Thursday 22 June – 18:00 PARADISE GARDEN**

#### ***Craig Bullock: United Kingdom***

Craig Bullock, MA, International floral designer and artist was the youngest to ever become a NAFAS National demonstrator at age 24. Over the last 36 years Craig has demonstrated and taught around the globe in countries such as Australia, Barbados, Belgium, France, Germany, Hong Kong, Japan, Kenya, Malta, New Zealand, Pakistan, Russia, South Africa, Spain, and the USA. Craig is also a judge of floral art and his creativity and showmanship have been featured in many books and magazines, primarily the NAFAS magazine "Flower Arranger". Craig enjoys working with natural materials and sees his floral work as an extension of his art work and enjoys challenging ideas whilst respecting tradition. He was included in the organizing team for shows and exhibitions at Chicheley, Oxford, Canterbury and Southwark Cathedrals in 2011, 2013, 2014 and 2015. Craig was awarded several Gold and Best in Show awards at RHS Chelsea, other UK national competitions and international Wafa shows in New Zealand and Glasgow. He gained a BA and MA from Manchester Metropolitan University in 2007 and will take over as Area Chairman of the NAFAS North West Area in November 2017.

#### ***Dr. Solomon Leong: Hong Kong***

Dr. Solomon Leong is a highly recognized Hong Kong based floral designer. International media, such as the BBC, have described him as "extraordinary" and "striking". Dr. Leong's professional life includes competing in international shows, conducting workshops and contributing regularly to fashion magazines like Elle, Cosmopolitan and Marie Claire in China. He has consistently received several gold, silver, bronze and special awards at international flower shows in China, Japan, Malaysia, Singapore and the UK. Dr. Leong is a doctor of philosophy in cultural studies, which gives him extensive knowledge of cultures and history in relation to floral art. He is a successful commentator of international floral designs on radio and television shows world-wide and also has extensive experience as an international judge. He is director of SOLOMON BLOEMEN Bespoke Floral Design Studio in Hong Kong providing expert floral services for a distinguished clientele. He is a member of the World Flower Council Hong Kong chapter, President of the Hong Kong Flower Club and Chairman of the Hong Kong Association of Flower Arranging Societies. He has published a flower magazine called "Solomon's Blooming Chic" in Chinese.

### **Demonstration 2 Friday 23 June – 18:00 ENTENTE CORDIALE**

#### ***Marie Françoise Déprez: France***

An International teacher, demonstrator and judge who runs her own school "Jeux de Fleurs International Floral Art Institute". Madame Déprez uses her social work skills to motivate creativity and style to produce first class floral art. She has travelled widely demonstrating and training in countries like Argentina, Australia, Belgium, Brazil, Hong Kong, Holland, Ireland, Italy, Japan, New Zealand, Uruguay, U.S.A., Russia, UK and Oman. She has organized and promoted international floral art competitions in Bourg-en-Bresse in 2000, 2003, 2006 and won prizes at flower shows in Monaco, Toronto, Brussels and Paris.

Madame Déprez has authored five books on floral art, namely Passion Florale, Table Design, Jeux de Fleurs, Floral Love and Floral Fantaisie.

### ***William Dixon: United Kingdom***

William (Bill) Dixon started his working career as an Interior Designer and continued his own successful business in Lancashire until his recent retirement. However, in the early 1990's he discovered the joy of flower arranging which led him to obtain a City and Guilds qualification in floral art. His love for the art form and his natural creativity carried him on to become a lead designer, NAFAS national demonstrator and teacher in the UK and several countries abroad. Bill was part of the UK North West Area team at Chelsea 2011 and led the RHS Tatton Flower Show team in 2014 achieving gold medals at both of these shows. He has won several other gold medals at National and World Shows, and was part of the design team for Winchester Cathedral's Flower Festival in 2015. He has been selected to be lead designer for Blackburn Cathedral's Flower Festival in 2016.

## **NATIONAL DEMONSTRATIONS**

**Thursday 22nd June 2017 – 11.00**

### ***Joan Linton: Heritage***

Joan is a professional florist who has a passion for gardening and photography. She has organized flower shows and displays for many Church festivals in Barbados, and is always ready and willing to give her talent to any church in need of floral beauty for their celebrations.

She has won numerous medals at home and a Gold medal at the "Canada Blooms" International Flower Show, as well as a bronze medal at the Chelsea Flower Show. She enjoys interior decorating and is an avid collector of art and local antiques.

### ***Jennifer Weetch: A Floral Journey***

Jennifer has been a keen flower arranger for over 40 years. She has participated successfully at national, regional and international level, her highest achievement being Gold and Best in Show at Chelsea. She has been totally involved with the local clubs having served as Treasurer and President of BFAS and a valuable member of BAFA. She has graciously consented to serve in the capacity as Vice President of WAFA Barbados.

Jennifer is very excited that Barbados will be hosting the World Flower Show and looks forward to welcoming all her friends to her beautiful homeland.

### ***Anthony Tang Kai: Tropical Splendour***

Anthony Tang Kai was born in Trinidad and has been involved in horticulture from an early age. He is a member of the Horticultural and Orchid Societies where he has served as President and is also an accredited judge. He has participated in shows both regionally and internationally as an exhibitor and a judge and has recently been giving workshops on orchid culture. He is passionate about conservation and the preservation of the environment.



**LECTURES (see FORM D for booking tickets)**

**Friday 23 June – 11.00**

***Title: Barbados – The Gardens of Paradise, Past and Present***

***Lecturer - Professor Sir Henry Fraser***

Senator Professor Emeritus Sir Henry Fraser is retired Dean of the Faculty of Medical Sciences and Founding Director of the Chronic Disease Research Centre of the University of The West Indies, Cave Hill Campus, Barbados. He is author of more than 100 medical and scientific papers on medical education, hypertension, obesity, drug treatment, health of the elderly and other subjects, and has been a Sunday columnist for many years, currently writing Things that Matter in the Sunday Advocate. Public Orator, Cave Hill Campus (1992 – 2010) and National Public Orator since 1998.

He has had parallel careers in Architectural History and as writer, artist, public orator and TV presenter, is best known for his many books on Barbados heritage and architecture, TV series Treasures of Barbados and recent series Pillars of Worship and Parliament 375 for CBC-TV. Past President of the Barbados National Trust, he chaired the Task Force for the nomination of Historic Bridgetown and its Garrison as a World Heritage site, and is now Chairman of the Task Force for Preservation of Barbados' Built Heritage and the Barbados National Trust's Sentinel Committee. He was Knighted November 2014.

**Saturday 24 June – 11.00**

***Title: Gender and Social Change in Post-Independent Barbados***

***Lecturer - Professor Eudine Barriteau, GCM***

Professor Violet Eudine Barriteau is a Grenadian born Caribbean feminist, scholar and activist with considerable experience in research, holding senior executive positions and administering and coordinating several regional projects at the University of The West Indies, Cave Hill Campus. She has been awarded many academic scholarships including awards from international universities in Toronto and Sweden as well as national and regional awards.

Professor Barriteau holds a Ph.D. in Political Science from Howard University, and an MPA in Public Sector Financial Management from New York University. She was appointed Principal of The University of the West Indies, Cave Hill Campus (UWI-CHC) on May 1, 2015, after previously holding positions as first head of the Centre for Gender and Development Studies, Deputy Principal and Principal, Open Campus UWI-CHC, before being appointed to her present post.

Country awards received include the Gold Crown of Merit (GCM) of Barbados for her invaluable contribution to gender and development and the Order of Grenada Gold Award for Excellence. She has written over thirty book chapters and peer-reviewed journal articles. Her research interests include: Caribbean Feminist Thought; Economic Analysis; and Theorizing Gender Systems in the Caribbean Political Economy.

**Sunday 25 June – 16.00**

***Title: Bajan Folklore***

***Lecturer - G. Addington Forde***

Barbadian Folklorist, Mr. G. Addington Forde, started his career as a teacher of English Literature after completing his tertiary education at the University of the West Indies, Barbados. His love of research in the cultural aspects of Barbados led him to the position of Cultural Officer at the National Cultural Foundation (NCF) specializing in folklore. He co-authored the work "A to Z of Barbadian Heritage", has published many articles on cultural norms, values and practices for the NCF and spoken about these on the local radio

station, the Caribbean Broadcasting Corporation and contributed to the Nation newspaper on subjects such as “Kites”, “De Mortar-Pestle: A collection of Barbadian proverbs” and “Folk Beliefs of Barbados”. Mr. Forde is also a poetry writer and his features in this genre have also appeared in the Nation newspaper, Bim Magazine and “Voices 1”, an anthology of Barbadian Writing.

The multi-talented Mr. Forde has done performances of his work on stage and television both as writer, producer and actor. He has been instrumental in reviving the African board game “Warri” now played in Barbados, Antigua and Barbuda.

## BARBADOS TOURS

*There are a number of tours available in Barbados which can be booked via the tours website . Here are a few of the tours recommended. You may also check the tours website for full details and further tours.*

Remac Tours	Description	Cost	Date
<i>Northern Highlights of Barbados</i>	Guided Half Day Tour 4 – 5 Hrs	<b>US\$78.00</b>	
<i>Cave and Flowers</i>	Guided Half Day Tour 4 – 5 Hrs	<b>US\$95.00</b>	Thursday June 15, 2017
<i>Historical &amp; Floral Tour</i>	Guided Half Day Tour 4 – 5 Hrs	<b>US\$100.00</b>	Friday June 16, 2017
<i>Scenic Barbados Tour</i>	Guided 6 – 7 Hrs	<b>US\$90.00</b>	Sunday 18 June, 2017
<i>Northern Highlights of Barbados</i>	Guided Half Day Tour 4 – 5 Hrs	<b>US\$78.00</b>	Thursday 22 June, 2017
<i>Cave and Flowers</i>	Guided Half Day Tour 4 – 5 Hrs	<b>US\$95.00</b>	Friday 23 June, 2017
<i>Scenic Barbados Tour</i>	Guided 6 – 7 Hrs	<b>US\$90.00</b>	Saturday 24 June, 2017
<i>Historical &amp; Floral Tour</i>	Guided Half Day Tour 4 – 5 Hrs	<b>US\$100.00</b>	Sunday 25 June, 2017

Remac Tours - [remactours@gmail.com](mailto:remactours@gmail.com)

National Heroes Gallery and Museum of Parliament – email: [parliament\\_museum@caribsurf.com](mailto:parliament_museum@caribsurf.com)

Cricket Legends of Barbados - [www.cricketlegendsbarbados.com](http://www.cricketlegendsbarbados.com)

Atlantis Submarine Sea Tours - [www.barbados.atlantissubmarines.com](http://www.barbados.atlantissubmarines.com)

Barbados Golf Club - [www.barbadosgolfclub.com](http://www.barbadosgolfclub.com)

Suntours - [www.suntoursbarbados.com](http://www.suntoursbarbados.com)



## HOTEL ACCOMMODATION

Listed are hotels at which you may make bookings. Bookings should be made directly with the hotels. Please note promo codes. Further information on accommodation can be found on the hotels website.

There are no hotels in the immediate vicinity of the LESC. However most hotels are within 1 – 15 Km from the LESC.

### *Ocean 2*

6.6 km from LESC  
www.oceantwobarbados.com  
Use Code 'WAFA 2017'

### *South Beach Hotel*

5.5 km from LESC  
www.oceanhotels.com  
Use Code 'WAFA 2017'

### *Divi South Winds*

6.1 km from LESC  
www.diviresorts.com

### *Hilton Hotel*

6 km from LESC  
www.hiltonbarbadosresort.com

### *The House*

12km from LESC  
www.eleganthotels.com

### *Infinity on the Beach*

3 km from LESC  
www.infinityonthebeach.com

### *Accra Beach Hotel*

5.5 km from LESC  
reservations@accrabeachhotel.com

### *Waves Hotel*

11 km from LESC  
www.eleganthotels.com

### *Crystal Cove*

12 km from LESC  
www.eleganthotels.com  
All Inclusive

### *Beach View Hotel*

12 km from LESC  
www.beachviewbarbados.com

### *Tamarind Hotel*

12 km from LESC  
www.eleganthotels.com

### *Colony Club*

15 km from LESC  
www.eleganthotels.com  
All Inclusive

### *Bougainvillea Beach Resort*

6.3 km from LESC  
www.bougainvillearesort.com

### *Yellow Bird Hotel*

6.3 km from LESC  
www.yellowbirdbarbados.com

### *Sea Breeze Hotel*

6.3 km from LESC  
www.sea-breeze.com  
Use Code 'WAFA 2017'  
All inclusive

### *Savannah Beach Hotel*

6.2 km from LESC  
www.savannahbarbados.com

### *Southern Palms Hotel*

6.6 km from LESC  
reservations@southernpalms.net  
Ref. World Flower Show 2017

### *Sugar Bay Hotel*

5.3 km from LESC  
www.sugarbaybarbados.com  
All inclusive

### *Butterfly Beach Hotel*

6.3 km from LESC  
reservations@butterflybeach.com  
Use Code WAFA

### *Coral Mist Hotel*

5.3 km from LESC  
www.coralmistbarbados.com

### *Courtyard Marriotts*

6.2 km from LESC  
www.courtyardbarbados.com

### *Coral Sands Hotel*

5.3 km from LESC  
www.coralsandsresort.com

### *Turtle Beach*

6.6 km from LESC  
www.eleganthotels.com  
All inclusive

### *Radisson Aquatica Resort*

5.3 km from LESC  
www.radisson.com/barbados

### *Ocean 15 Hotel*

6.6 km from LESC  
reservations@ocean15hotel.com  
Use Code 'WAFA'



SAY IT WITH FLOWERS TO CELEBRATE ALL OCCASIONS.



**Located at Worthing, Christ Church, Barbados**

**We are wholesalers of a range  
of local exotic tropical blooms and fresh imported flowers and foliage.**

**Call us at 246-435-9774**

**[foreverflowers@caribsurf.com](mailto:foreverflowers@caribsurf.com)**

**[www.foreverflowersbarbados.com](http://www.foreverflowersbarbados.com)**



---

**WORLD ASSOCIATION OF FLORAL ARTISTS**  
**BARBADOS 2014-2017**

---